

TECHNICAL MANUAL

**ORGANIZATIONAL, DIRECT SUPPORT, AND
GENERAL SUPPORT MAINTENANCE REPAIR
PARTS AND SPECIAL TOOLS LIST
(INCLUDING DEPOT MAINTENANCE REPAIR PARTS AND
SPECIAL TOOLS)
FOR
RADIO SET AN/ARC 115
FSN 5821 935-5072)**

**HEADQUARTERS, DEPARTMENT OF THE ARMY
JUNE 1974**

**Organizational, Direct Support, and General Support Maintenance Repair Parts and Support
Tools List (Including Depot Maintenance Repair Parts and Special Tools) For**

RADIO SET AN/ARC-1 15 (FSN 5821-935-5072)

Current as of 27 December 1973

		Page	Illus Figure
Section I.	Introduction.....	1-1	
II.	Repair parts list.....	2-1	
Group 01	(A1) Front section	2-1	
	0101 (A1A 1) Tuning control assembly	2-1	1
	0102 (A1A 1A4) Tuner matrix "C/D" deck assembly	2-2	1
	0103 (A1A 1A2) Tuner matrix "A" deck assembly	2-2	1
	0104 (A1A 1A3) Tuner matrix "B" deck assembly.....	2-2	1
	0105 (A1A3) RF amplifier and mixer assembly	2-3	2
	0106 (A1A3A4) Guard receiver oscillator assembly	2-3	2
	0107 (A1A3A1) Main receiver, RF amplifier and mixer assembly.....	2-3	2
	0108 (A1A3A2) Guard RF amplifier and mixer assembly	2-5	2
	0109 (A1A3A3) Noise generator assembly	2-5	2
	0110 (A1A2A1) Switched crystal oscillator assembly	2-5	3
	0111 (A1A2A2) Dividers, 10 MC oscillator det assembly	2-5	3
	0112 (A1A2A3) VCO and D-A converter assembly.....	2-5	3
	0113 (A1A2A4) Transmit audio and comparator assembly	2-5	3
	0114 (A1A2A5, A1A2A11) IF amplifier assembly	2-5	3
	0115 (A1A2A6) Second IF detector and AGC AMP assembly	2-5	3
	0116 (A1A2A7, A1A2A9) Squelch circuit assembly	2-5	3
	0117 Audio amplifier assembly	2-5	3
	0118 (A1A2A12) Chassis and cable assembly	2-7	3
02	(A2) Rear section	2-7	
	0201 (A2A3) Modulator assembly	2-7	4
	0202 (A2A4) Exciter Power AMP assembly	2-9	4
	0203 (A2A2) Power supply	2-9	4
	0204 (A2A 1) RF coupler and filter assembly	2-9	4,5
	99 Bulk material	2-13	
Section III.	Special tools list.....	3-1	
	Filter relay assembly and VSWR load 10:l	3-1	6
	Radio Set: front and rear AN/AC-115.....	3-1	7
IV.	Federal stock number and part number index	4-1	

*This manual supersedes TM 11-5821-260-20P, 16 December 1970 and TM 11-5821-260-35P, 3 February 1971, including all changes.

SECTION I INTRODUCTION

1. Scope

This manual lists repair parts; special tools; test, measurement, and diagnostic equipment (TMDE); and other support equipment required for performance of organizational, direct support, and general support maintenance of the AN/ARC-115.

2. General

This Repair Parts and Special Tools List is divided into the following sections;

a. Section II. Repair Parts List. A list of repair parts authorized for use in the performance of maintenance. The list also includes parts which must be removed from replacement of the authorized parts. Parts list are composed of functional groups in ascending numerical sequence, with the parts in each group listed in figure and item number sequence. Bulk materials are listed in FSN sequence.

b. Section III. Special Tools List. A list of special tools, TMDE, and support equipment authorized for the performance of maintenance.

c. Section IV. Federal Stock Number and Part Number Index. A list, in ascending numerical sequence, of all Federal stock numbers appearing in the listings, followed by a list, in alphanumeric sequence, of all part numbers appearing in the listings. Federal stock number and part numbers are cross-referenced to each illustration figure and item number appearance.

3. Explanation of Columns

The following provides an explanation of columns found in the tabular listing:

a. Illustration. This column is divided as follows:

(1) *Figure number.* Indicates the figure number of the illustration in which the item is shown.

(2) *Item number.* The number used to identify each item called out in the illustration.

b. Source, Maintenance, and Recoverability Codes (SMR).

(1) *Source code.* Source codes are assigned to support items to indicate the manner of acquiring support items for maintenance, repair, or overhaul of end item. Source codes are entered in the first and second positions of the Uniform SMR Code format as follows:

<i>Code</i>	<i>Definition</i>
-------------	-------------------

PA-Item procured and stocked for anticipated or known usage.
--

PE-Support equipment procured and stocked for initial issue or outfitting to specified maintenance repair activities.

MD-Item to be manufactured or fabricated at the depot maintenance level.
--

XA-Item is not procured or stocked because the requirements for the item will result in the replacement of the next higher assembly.
--

XD-A support item that is not stocked. When required, item will be procured through normal support channels.
--

NOTE

Cannibalization or salvage may be used as a source of supply for any items source coded above except those coded XA, XD, and aircraft support items as restricted by AR 700-42.

(2) *Maintenance code.* Maintenance codes are assigned to indicate the levels of maintenance authorized to USE and REPAIR support items. The maintenance codes are entered in the third and fourth positions of the Uniform SMR Code Format as follows-

(a) The maintenance code entered in the third position indicates the lowest maintenance level authorized to remove, replace, and use the support item. The maintenance code entered in the third position indicates one of the following levels of maintenance.

<i>Code</i>	<i>Application/Explanation</i>
-------------	--------------------------------

O-Support item is removed, replaced, used at the organizational level.
--

F-Support item is removed, replaced, used at the direct support level.
--

H-Support item is removed, replaced, used at the general support level.
D-Support items that are removed, replaced, used at depot, mobile depot, specialized repair activity only.

NOTE

Codes "I" and "F" will be considered the same by direct support units.

(b) The maintenance code entered in the fourth position indicates whether the item is to be repaired and identifies the lowest maintenance level with the capability to perform complete repair (i.e., all authorized maintenance functions). This position will contain one of the following maintenance codes:

<i>Code</i>	<i>Application/Explanation</i>
O	The lowest maintenance level capable of complete repair of the support item is the organizational level.
F	The lowest maintenance level capable of complete repair of the support item is the direct support level.
H	The lowest maintenance level capable of complete repair of the support item is the general support level.
D	The lowest maintenance level capable of complete repair of the support item is the depot level, performed by depot.

(3) *Recoverability code.* Recoverability codes are assigned to support items to indicate the disposition action on unserviceable items. The recoverability code is entered in the fifth position of the uniform SMR Code Format as follows-

<i>Recoverability Code</i>	<i>Definition</i>
Z	Nonrepairable item. When unserviceable, condemn and dispose at the level indicated in position 3.
D	Repairable item. When beyond lower level repair capability, return to depot. Condemnation and disposal not authorized below depot level.
L	Repairable item. Repair, condemnation, and disposal not authorized below depot/Specialized Repair Activity level.
A	Item requires special handling or condemnation procedures because of specific reasons (i.e., precious metal content, high dollar value, critical material or hazardous material). Refer to appropriate manual/directives for specific instructions.

c. *Federal Stock Number.* Indicates the Federal stock number assigned to the item and will be used for requisitioning purposes.

d. *Part Number.* Indicates the primary number used by the manufacturer (individual, firm, corporation, or Government activity), which controls the design and characteristics of the item by means of its engineering drawings, specifications standards, and inspection requirements, to identify an item or range of items.

NOTE

When a stock numbered item is requisitioned, the repair part received may have a different part number than the part being replaced.

e. *Federal Supply Code for Manufacturer (FSC M).* The FSC M is a 5-digit numeric code listed in SB 708-42 which is used to identify the manufacturer, distributor, or Government agency, etc.

f. *Description.* Indicates the Federal item name and, if required, a minimum description to identify the item. Items that are included in kits and sets are listed below the name of the kit or set with the quantity of each item in the kit or set indicated in the quantity incorporated in unit column. When the part to be used differs between serial numbers of the same model. The effective serial numbers are shown as the last line of the description.

g. *Unit of Measure (U/M).* Indicates the standard of the basic quantity of the listed item as used in performing the actual maintenance function. This measure is expressed by a two-character alphabetical abbreviation (e.g., ea, in, pr, etc.). When the unit of measure differs from the unit of issue, the lowest unit of issue that will satisfy the required units of measure will be requisitioned.

h. *Quantity Incorporated in Unit.* Indicates the quantity of the item used in the breakout shown on the illustration figure, which is prepared for a functional group. A "V" appearing in this column in lieu of a quantity indicates that specific quantity is applicable, (e.g., shims, spacers, etc).

4. Special Information

The following publications pertain to the AN/ARC-115 and its components:

TM 11-5821-260-24P

TM 11-5821-260-20---Radio Set AN/ARC-115

TM 11-5821-260-35---Radio Set AN/ARC-115

5. How to Locate Repair Parts

a. When Federal Stock Number or Part Number is Unknown:

(1) *First.* Using the table of contents, determine the functional group within which the repair part belongs. This is necessary since illustrations are prepared for functional groups and listings are divided into the same groups.

(2) *Second.* Find the illustration covering the functional group to which the repair part belongs.

(3) *Third.* Identify the repair part on the illustration and note the illustration figure and item number of the repair part.

(4) *Fourth.* Using the Repair Parts Listing, find the figure and item number noted on the illustration.

b. When Federal Stock Number or Part Number is Known:

(1) *First.* Using the Index of Federal Stock Numbers and Part Numbers, find the pertinent Federal stock number or part number. This index is in ascending FSN sequence followed by a list of part numbers in ascending alphanumeric sequence, cross-referenced to the illustration figure number and item number.

(2) *Second.* After finding the figure and item number, locate the figure and item number in the repair parts list.

6. Abbreviations

Not applicable.

7. Recommendation for Maintenance Publications Improvements

Report of errors, omissions, and recommendations for improving this publication by the individual user is encouraged. Reports should be submitted on DA Form 2028 (Recommended Changes to Publications and Blank Forms) and forwarded direct to Commander, US Army Electronics Command, ATTN: AMSEL-MA-A, Fort Monmouth, NJ 07703.

SECTION II

REPAIR PARTS LIST (Continued)

(1) ILLUSTRATION		(2)	(3)	(4)	(5)	(6)	(7)	(8)
(a) FIG NO.	(b) ITEM NO.	SMR CODE	FEDERAL STOCK NUMBER	PART NUMBER	FSCM	DESCRIPTION <i>USABLE ON CODE</i>	U/M	QTY INC IN UNIT
GROUP 01 FRONT SECTION GROUP 0101								
1	1	PAHHD	5821-724-1685	SM-B-618025	80063	TUNING CONTROL ASSY	EA	1
1	1A	PAFZZ	5821-789-3815	SM-E-618092-1	80063	PANEL	EA	1
1	2	PAFZZ	5305-717-6950	MS51963-9	96906	SETSCREW	EA	6
1	3	PAFZZ	5355-880-5549	SM-C-618407	80063	KNOB	EA	1
1	4	PAFZZ	5305-719-5346	MS51963-35	96906	SETSCREW	EA	4
1	5	PAFZZ	5355-880-5548	SM-C-617814	80063	KNOB	EA	2
1	6	PAFZZ	5305-719-5342	MS51963-34	96906	SETSCREW	EA	1
1	7	PAFZZ	5305-719-5349	MS 51963-37	96906	SETSCREW	EA	1
1	8	PAFZZ	5355-880-5546	SM-D-595979-3	80063	KNOB	EA	1
1	9	PAFZZ	5310-022-6331	SM-B-618257	80063	SCREW, SPECIAL COATED	EA	2
1	10	PAFZZ	5310-929-6395	MS35338-136	96906	WASHER, LOCK	EA	2
1	11	PAHZZ	5340-598-1493	MS16632-4018	96906	RING, RETAINING	EA	1
1	12	PAHZZ	5310-143-5661	SM-C-617837-1	80063	WASHER, FLAT	EA	2
1	13	PAHZZ	5821-091-9160	SM-B-618398	80063	BEARING, SUPPORT	EA	1
1	14	PAHZZ	5985-110-9288	SM-B-618008	80063	SHAFT, ASSEMBLY	EA	1
1	14A	PAHZZ	5310-115-6273	SM-B-618257-2	80063	SCREW, SPECIAL COATED	EA	8
1	14B	PAHZZ	5310-929-6395	MS35338-136	96906	WASHER, LOCK	EA	3
1	15	PAHZZ	5305-763-7822	MS51959-14	96906	SCREW, MACHINE	EA	2
1	16	PAHZZ	5340-721-8187	MS16624-1018	96906	RING, RETAINING	EA	2
1	17	PAHZZ	5340-113-3848	SM-C-618053-1	80063	SHIM	EA	V
1	18	PAHZZ	5310-113-8415	SM-C-618048-2	80063	WASHER, TURNS COUNTING	EA	1
1	19	PAHZZ	5310-792-3555	SM-C-618048-1	80063	WASHER, TURNS COUNTING	EA	3
1	20	PAHZZ	5340-151-7036	SM-C-618089	80063	RING, STOP	EA	1
1	21	PAHZZ	5310-143-5649	SM-C-596378-1	80063	WASHER, FLAT	EA	V
1	22	PAHZZ	3120-116-1474	SM-C-618064	80063	BEARING, SHIELD	EA	2
1	22A	PAHZZ	5305-054-9228	70A3810406-480	00011	SCREW, MACHINE	EA	2
1	22B	PAHZZ	5310-113-8434	SM-C-617837-5	80063	WASHER, FLAT	EA	2
1	23	PAHZZ	5305-717-6955	MS51963-1	96906	SETSCREW	EA	4
1	24	MDHZZ		SM-B-692955	80063	COLLAR, SHAFT	EA	1
1	25	PAHZZ	3020-107-3221	SM-D-617888-2	80063	GEAR, HELICAL	EA	1
1	26	PAHZZ	3040-181-3214	SM-C-618548	80063	SHAFT, KNOB, LT	EA	1
1	27	PAHZZ	5340-793-1256	SM-C-618500	80063	GEAR, SPUR	EA	1
1	28	PAHZZ	3120-809-6561	SM-C-618066-2	80063	BEARING, SLEEVE	EA	1
1	29	PAHZZ	6680-150-6914	SM-D-595976-2	80063	COUNTER, ROTARY	EA	1
1	30	PAHZZ	5340-793-1664	SM-C-617832-2	80063	ROD, CONTOUR, STOP	EA	1
1	31	PAHZZ	5315-797-5206	SM-B-595940-1	80063	PIN, LOCK, EXPANSION	EA	2
1	32	PAHZZ	3020-106-9892	SM-D-618082	80063	GEAR, CLUSTER	EA	2
1	33	PAHZZ	5930-115-8522	SM-C-617856	80063	SWITCH, ROTARY	EA	1
1	34	PAHZZ	5310-143-5680	SM-B-597932-4	80063	WASHER, SPRING TENSION	EA	2
1	35	PAHZZ	5930-520-5179	SM-D-618087	80063	DRIVER, SWITCH	EA	1

SECTION II

REPAIR PARTS LIST (Continued)

(1) ILLUSTRATION		(2)	(3)	(4)	(5)	(6)	(7)	(8)
(a) FIG NO.	(b) ITEM NO.	SMR CODE	FEDERAL STOCK NUMBER	PART NUMBER	FSCM	DESCRIPTION <i>USABLE ON CODE</i>	U/M	QTY INC IN UNIT
1	36	PAHZZ	5895-704-9698	SM-B-595947	80063	GEAR, PLASTIC	EA	2
1	37	PAHZZ	5340-793-1712	SM-C-617878-3	80063	SPACER, TUBULAR	EA	3
1	38	PAHZZ	3040-091-9133	SM-D-617842-2	80063	GEAR SHAFT	EA	1
1	39	MDHZZ		SM-B-618392	80063	PLATE, SWITCH	EA	2
1	40	PAHZZ	5310-143-5663	SM-C-617837-3	80063	WASHER, FLAT	EA	10
1	41	PAHZZ	5310-928-2690	MS 35338-134	96906	WASHER, LOCK	EA	10
1	42	PAHZZ	5305-812-6079	NAS 1635-02-20	80205	SCREW, MACHINE	EA	6
1	43	PAHZZ	5930-116-2769	SM-C-618218	80063	SWITCH, ROTARY	EA	1
1	44	PAHZZ	5930-116-2768	SM-B-617809-2	80063	SWITCH, ROTARY	EA	2
1	45	PAHZZ	5970-134-0907	SM-C-597677	80063	INSULATOR, SWITCH	EA	2
1	46	PAHZZ		SM-B-617839	80063	PLATE, SWITCH	EA	2
1	47	PAHZZ	5305-012-0719	NAS 1635-00-8	80205	SCREW, MACHINE	EA	4
1	48	PAHZA	5821-091-9165	SM-B-618122	80063	TUNER MATRIX "C/D" DECK, ASSY GROUP 0102	EA	1
1	49	PAHZA	5821-091-9167	SM-B-618116	80063	TUNER MATRIX "A" DECK, ASSY GROUP 0103	EA	1
1	50	PAHZZ	5340-793-1273	SM-C-596095-12	80063	SPACER, SLEEVE	EA	3
1	51	PAHZZ	5305-054-5637	MS 51957-3	96906	SCREW, MACHINE	EA	1
1	52	PAHZA	5821-091-9166	SM-B-618119	80063	TUNER MATRIX "B" DECK, ASSY GROUP 0104	EA	1
1	53	PAHZZ	5305-411-0681	70A3210218-480	00011	SCREW, MACHINE	EA	3
1	54	PAHZZ	5999-061-3276	SM-A-617935-2	80063	CONTACT, ELECTRICAL	EA	55
1	55	PAHZZ	5935-168-4418	SM-C-632343	80063	SUPPORT, CONNECTOR	EA	1
1	56	PAHZZ	5935-115-8514	SM-A-617920-9	80063	CONNECTOR, PLUG	EA	1
1	57	PAHZZ	5935-134-5356	SM-A-617902-4	80063	CONNECTOR, PLUG	EA	1
1	58	PAHZZ	5821-168-3626	SM-C-632344	80063	SUPPORT, CONNECTOR	EA	1
1	59	PAHZZ	5930-116-2767	SM-B-617809-1	80063	SWITCH, ROTARY	EA	1
1	60	PAHZZ	3040-091-9134	SM-D-617842-1	80063	GEAR SHAFT	EA	1
1	61	PAHZZ	5340-793-1703	SM-C-617878-2	80063	SPACER, TUBULAR	EA	3
1	62	PAHZZ	5930-520-5179	SM-D-618087	80063	DRIVER, SWITCH	EA	1
1	63	PAHZZ	5930-115-8523	SM-C-617857	80063	SWITCH, ROTARY	EA	1
1	64	XAHZZ		SM-B-618546	80063	FRAME, COUNTER	EA	1
1	64	XAHZZ		MS-B-618080	80063	FRAME, COUNTER	EA	1
1	65	PAHZZ	5305-068-5414	SM16995-11	96906	SCREW, CAP, SCH	EA	3
1	66	PAHZZ	3020-106-9893	SM-C-618063	80063	SPROCKET	EA	1
1	67	PAHZZ	5315-797-5206	SM-B-595940-2	80063	PIN, LOCK, EXPANSION	EA	2
1	68	PAHZZ	3020-102-3768	SM-B-617829-5	80063	CHAIN, DRIVE	EA	1
1	69	PAHZZ	3020-102-3767	SM-D-617888-1	80063	GEAR, HELICAL	EA	1
1	70	PAHZZ	3120-809-6560	SM-C-618066-3	80063	BEARING, SLEEVE	EA	1
1	71	PAHZZ	5340-793-1256	SM-C-618550	80063	GEAR, SPUR	EA	1
1	72	PAHZZ	5355-181-1126	SM-C-618549	80063	SHAFT, KNOB, RT	EA	1

SECTION II

REPAIR PARTS LIST (Continued)

(1) ILLUSTRATION		(2)	(3)	(4)	(5)	(6)	(7)	(8)
(a) FIG NO.	(b) ITEM NO.	SMR CODE	FEDERAL STOCK NUMBER	PART NUMBER	FSCM	DESCRIPTION <i>USABLE ON CODE</i>	U/M	QTY INC IN UNIT
1	73	PAHZZ	5340-866-1471	MS 16632-4012	96906	RING, RETAINING	EA	3
1	74	PAFZZ	5930-059-2856	SM-A-595811-4	80063	SWITCH, PB	EA	1
1	75	PAHZZ	5310-807-1471	MS 21042L04	96906	NUT, SELF-LOCKING, HFX	EA	2
1	76	PAHZZ	5310-595-6211	MS 15795-803	96906	WASHER, FLAT	EA	2
1	77	XAHZZ		SM-B-618083	80063	PANEL	EA	1
1	78	PAFZZ	5310-933-8118	MS 35338-135	96906	WASHER, LOCK	EA	4
1	79	PAFZZ	5305-054-5656	MS 51957-22	96906	SCREW, MACHINE	EA	4
1	80	PAHZZ	5905-057-8737	SM-A-597813-5	80063	RESISTOR, VARIABLE	EA	1
1	81	PAHZZ	5905-057-8733	SM-A-597813-3	80063	RESISTOR, VARIABLE	EA	1
1	82	MDHZZ		SM-C-618889-1	80063	PLATE, MOUNTING-VARIABLE RESISTOR	EA	1
1	83	PAHZZ	5305-054-5636	MS 51957-2	96906	SCREW, MACHINE	EA	3
1	84	PAHZZ	5310-792-3548	SM-B-617939-3	80063	NUT, HEX	EA	2
1	85	PAHZZ	5310-113-8412	SM-B-595971-1	80063	WASHER, LOCK-INTERNAL TOOTH	EA	1
1	86	PAFFA	5821-142-5437	SM-E-618092-2	80063	WIRING PLATE AND LAMP ASSEMBLY GROUP 0105	EA	1
2	1	PAHHD	5821-724-1686	SM-B-618400	80063	RF AMPLIFIER AND MIXER ASSY	EA	1
2	1A	PAHZZ	5310-928-2690	MS 35338-134	96906	WASHER, LOCK	EA	30
2	2	PAHZZ	5305-054-5637	MS 51957-3	96906	SCREW, MACHINE	EA	28
2	3	PAHZZ	5310-143-5663	SM-C-617837-3	80063	WASHER, FLAT	EA	19
2	4	PAHZZ	5305-054-5643	MS 51957-9	96906	SCREW, MACHINE	EA	1
2	5	PAHZZ	5821-177-1584	SM-C-618826	80063	COVER, OSCILLATOR GROUP 0106	EA	1
2	6	PAHZA	5821-728-8084	SM-B-596140	80063	GUARD RCVR, OSCILLATOR ASSY	EA	1
2	7	PAHZZ	5305-054-5636	MS 51957-2	96906	SCREW, MACHINE	EA	6
2	8	XAHZZ		SM-B-618404	80063	PLATE RECEIVER	EA	1
2	9	PAHZZ	5935-114-8767	SM-A-617920-4	80063	CONNECTOR, PLUG	EA	1
2	10	PAHZZ	5305-054-5638	MS 51957-4	96906	SCREW, MACHINE	EA	2
2	11	PAHZZ	5999-062-1608	SM-A-617935-1	80063	CONTACT, ELECTRICAL	EA	7
2	12	PAHZZ	5310-880-7010	MS 21042L02	96906	NUT, SELF LOCKING, HEX	EA	4
2	13	PAHZZ	5310-011-6123	MS 35338-69	96906	WASHER, LOCK	EA	2
2	14	PAHZZ	5940-259-9057	SM-B-618033	80063	TERMINAL LUG	EA	1
2	15	XAHZZ		SM-E-618403	80063	CHASSIS GROUP 0107	EA	1
2	16	PAHOL	5821-926-3303	SM-B-618297	80063	MAIN RECEI .R, RF AMPLIFIER AND MIXER ASSY	EA	1
2	17	MDHZZ		SM-C-618439	80063	COVER, MAIN RECEIVER	EA	1
2	18	PAHZZ	5310-929-6395	MS 35337-79	96906	WASHER, LOCK	EA	16
2	19	PAHZZ	5340-793-1671	SM-B-618442	80063	BUSHING, GROUND	EA	4
2	20	PAHZZ	5995-056-8850	SM-A-597837-1	80063	CABLE ASSEMBLY, R F	EA	2
2	21	PAHZZ	5995-056-8848	SM-A-597837-2	80063	CABLE ASSEMBLY, R F	EA	2
2	22	PAHZZ	5820-782-5000	SM-A-595898-1	80063	CAPACITOR, FIXED	EA	8
2	23	PAHZZ	5821-091-9164	SM-C-618436	80063	PLATE, FILTER MOUNTING	EA	2

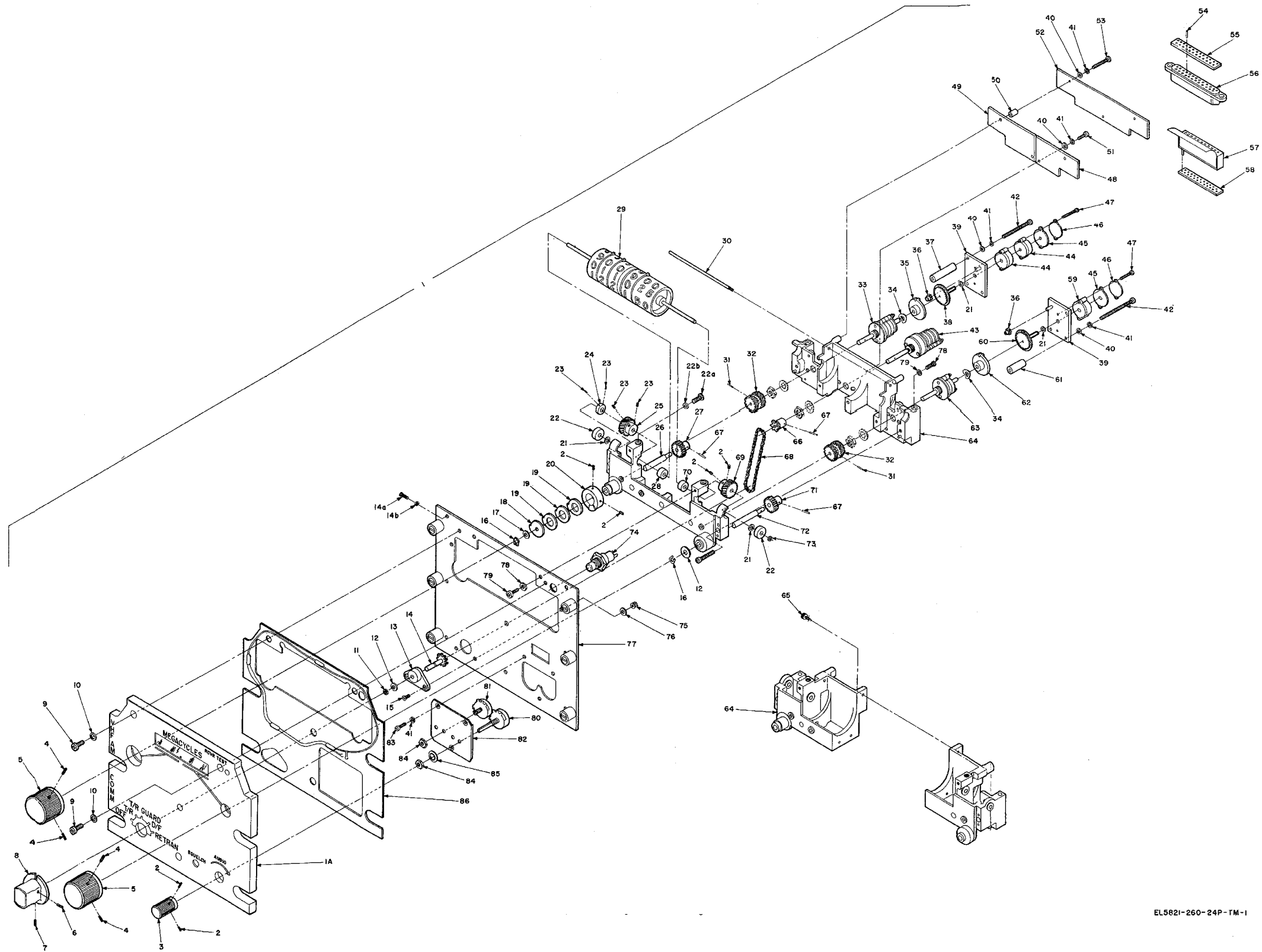

Figure 1. Tuning Control Assembly.
(Located in back of manual)

SECTION II

REPAIR PARTS LIST (Continued)

(1) ILLUSTRATION		(2)	(3)	(4)	(5)	(6)	(7)	(8)
(a) FIG NO.	(b) ITEM NO.	SMR CODE	FEDERAL STOCK NUMBER	PART NUMBER	FSCM	DESCRIPTION <i>USABLE ON CODE</i>	U/M	QTY INC IN UNIT
2	24	PAHZA	5821-727-4253	SMB-632012	80063	GROUP 0108 GUARD, RFAMP. AND MIXER ASSY	EA	1
2	25	PAHZZ	5310-938-2013	MS35649-224	96906	NUT, SELF LOCKING, HEX	EA	2
2	26	PAFZA	5821-727-4249	SMB-596143	80063	GROUP 0109 NOISE GENERATOR ASSY	EA	1
2	27	PAHZZ	5821-177-3510	SMC-618827	80063	COVER, NOISE GENERATOR	EA	1
3	1	PAFDL	5821-456-6002	SMB-692656	80063	GROUP 0110 SWITCHED CRYSTAL OSCILLATOR ASSY	EA	1
3	2	PAFDL	5821-142-5549	SMB-693079	80063	GROUP 0111 DIVIDERS, 10 MC OSC. DET. ASSY	EA	1
3	3	PAFZA	5821-142-5546	SMB-693081	80063	GROUP 0112 VCO AND D-A CONVERTER ASSY	EA	1
3	4	PAFDL	5821-727-4264	SMB-632225	80063	GROUP 0113 TRANSMIT AUDIO AND COMPARATOR ASSY	EA	1
3	5	PAFZA	5821-724-1707	SMB-59634 7	80063	GROUP 0114 IF AMPLIFIER ASSEMBLY	EA	2
3	6	PAFZA	5821-177-2907	SMB-692882	80063	GROUP 0115 SECOND IF DETECTOR AND AGC AMPLIFIER ASSY	EA	2
3	7	PAFZA	5821-177-2908	SMB-692735	80063	GROUP 0116 SQUELCH CIRCUIT ASSY	EA	2
3	8	PAFZA	5821-177-2908	SMB-618180	80063	GROUP 0117 AUDIO AMPLIFIER ASSY	EA	1
3	9	PADZZ	5305-727-8833	MS51959-3	96906	SCREW, MACHINE	EA	2
3	10	XADZZ		SMB-618201	80063	COVER, SYNTHESIZER	EA	1
3	11	PADZZ	5310-928-2690	MS35338-134	96906	WASHER, LOOK	EA	20
3	12	PADZZ	5305-054-5639	MS51957-5	96906	SCREW, MACHINE	EA	6
3	13	PADZZ	5320-168-7323	SMB-595946-10	80063	RIVER, SEMITUBULAR	EA	2
3	14	PADZZ	5935-134-5355	SMA-617902-3	80063	CONNECTOR, PLUG	EA	1
3	15	PADZZ	5310-880-7010	MS21042L02	96906	NUT, SELF LOCKING, HEX	EA	6
3	16	MDDZZ		SMC-618094	80063	BRACKET, CONNECTOR, MOUNTING	EA	1
3	17	XDDZZ		SMD-618266	80063	FLEXIBLE PRINTED WIRING SYNTHESIZER, MOTHERBOARD	EA	1
3	18	PADZZ	5999-168-4021	SMA-617935-5	80063	CONTACT, ELECTRICAL	EA	30
3	19	PADZZ	5935-134-5337	SMA-617920-10	80063	CONNECTOR, PLUG	EA	1
3	20	PADZZ	5310-143-5663	SMC-617837-3	80063	WASHER, FLAT	EA	6
3	21	PADZZ	5305-054-5638	MS51957-4	96906	SCREW, MACHINE	EA	4
3	22	PADDA	5821-815-9879	SMB-618206	80063	INTERCONNECTING BOARD	EA	1
3	23	PADZZ	5310-595-6761	MS15795-802	96906	WASHER, FLAT	EA	17
3	24	PADZZ	5305-054-5637	MS51957-3	96906	SCREW, MACHINE	EA	17
3	25	PADZZ	5999-062-1608	SMA-617935-1	80063	CONTACT, ELECTRICAL	EA	5
3	26	PADZZ	5999-168-4022	SMA-617935-3	80063	CONTACT, ELECTRICAL	EA	V
3	27	PADZZ	5935-419-5417	SMA-617934-2	80063	CONNECTOR, PLUG	EA	1

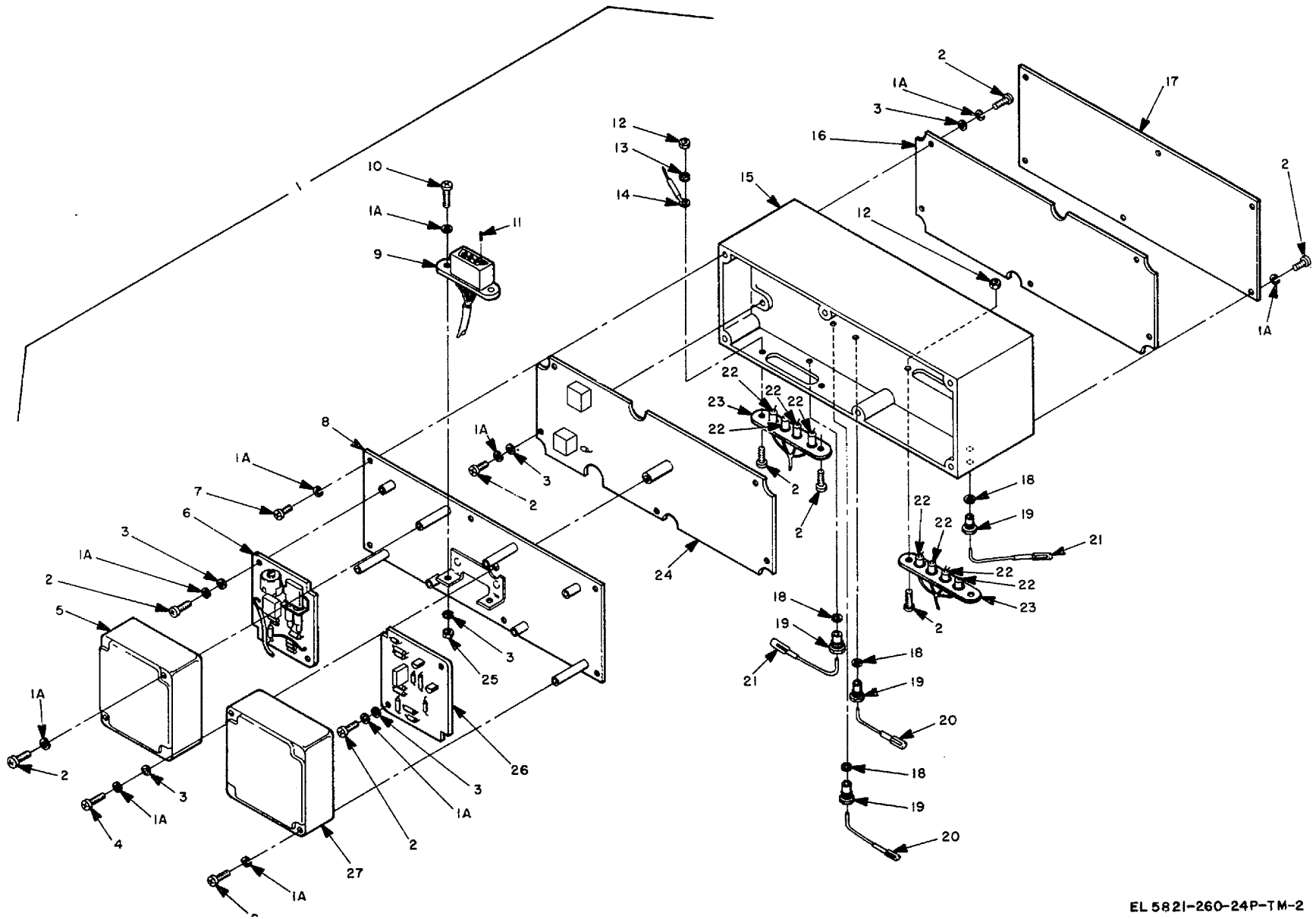
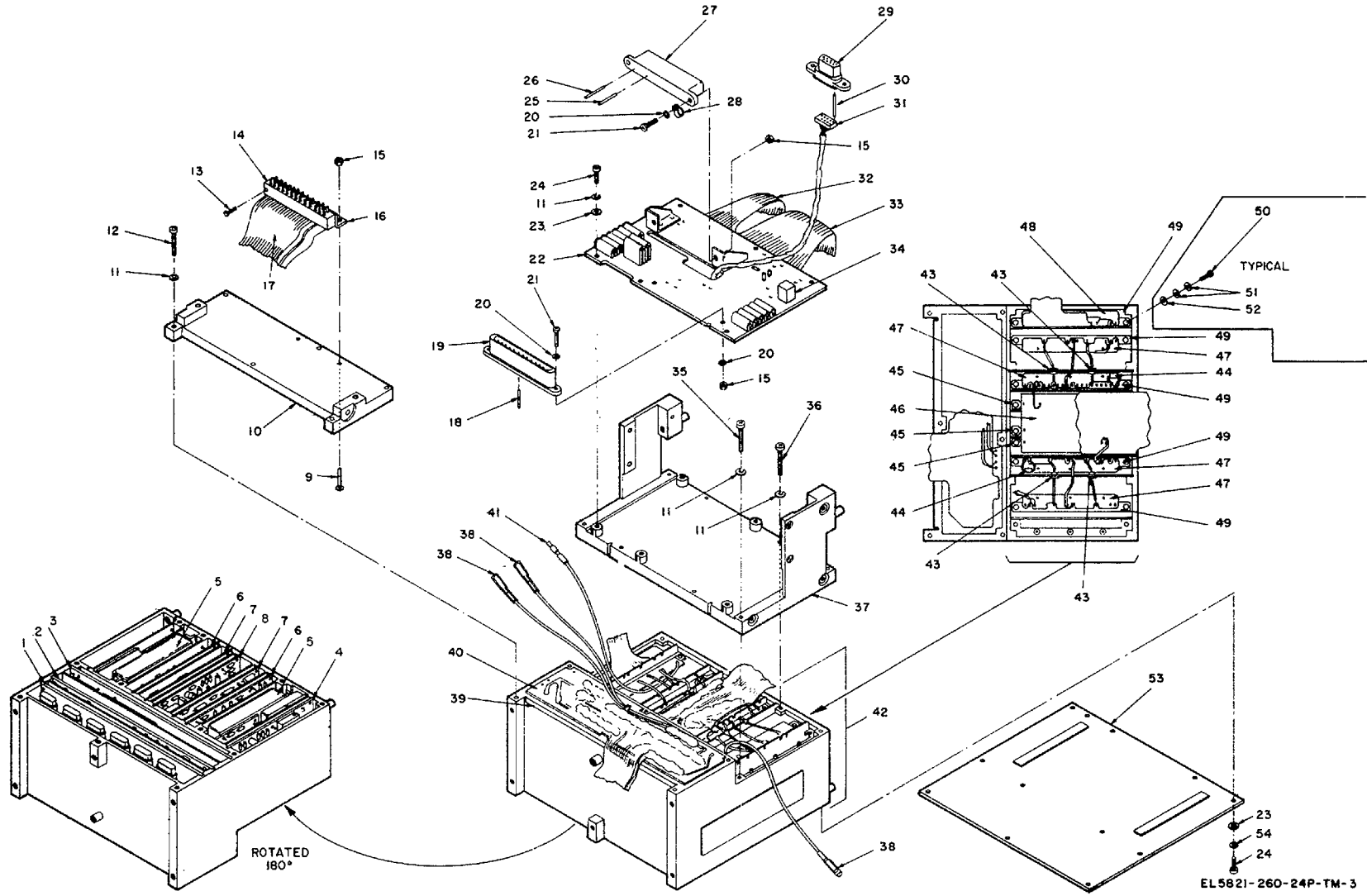

Figure 2. RF Amplifier and Mixer Assembly
2-6

SECTION II

REPAIR PARTS LIST (Continued)

(1) ILLUSTRATION		(2)	(3)	(4)	(5)	(6)	(7)	(8)
(a) FIG NO.	(b) ITEM NO.	SMR CODE	FEDERAL STOCK NUMBER	PART NUMBER	FSCM	DESCRIPTION <i>USABLE ON CODE</i>	U/M	QTY INC IN UNIT
3	28	PADZZ	5340-874-2451	SMB-618683-3	80063	CLAMP, LOOP	EA	1
3	29	PADZZ	5935-763-0858	SMA-617920-3	80063	CONNECTOR, RECEPTACLE	EA	1
3	30	PADZZ	5999-061-3276	SMA-617935-2	80063	CONTACT, ELECTRICAL	EA	7
3	31	PADZZ	5935-168-7997	SM-C-632345	80063	SUPPORT, CONNECTOR	EA	1
3	32	PADZZ	5995-168-3806	SMD-618638	80063	PRINTED CABLE ASSEMBLY	EA	1
3	33	PADZZ	5995-168-3805	SMD-618639	80063	PRINTED CABLE ASSEMBLY	EA	1
3	34	PADZZ	5905-763-4738	SMA-595862-202	80063	RESISTOR, VAR	EA	1
3	35	PADZZ	5305-054-5641	MS51957-7	96906	SCREW, MACHINE	EA	4
3	36	PADZZ	5305-054-5640	MS51957-6	96906	SCREW, MACHINE	EA	6
3	37	PADZZ	5821-177-3511	SMB-618203	80063	COVER, RCVR	EA	1
3	38	PADZZ	5995-056-8848	SMA-597837- 2	80063	CABLE ASSEMBLY, R F	EA	3
3	39	PADZZ	5970-168-4271	SM-C-692753	80063	INSULATOR	EA	1
3	40	PADZZ	5910-782-4962	SMB-618141	80063	CAPACITOR ASSEMBLY	EA	1
3	41	PADZZ	5995-056-8850	SMA-595837-1	80063	CABLE ASSEMBLY, R F	EA	1
						GROUP 0118		
3	42	PAHDL	5821-724-1690	SMB-618880	80063	CHASSIS AND CABLE ASSEMBLY	EA	1
3	43	PADZZ	5910-733-6687	SMA-595791-3	80063	CAPACITOR, FXED	EA	4
3	44	PADZZ	5910-168-3466	ML105C103M	96905	CAPACITOR, FIXED	EA	2
3	45	PADZZ	5935-168-4125	SMA-595807-2	80063	CONNECTOR, ELECTRICAL	EA	3
3	46	PADZZ	5821-177-3504	SMD-632010	80063	PRINTED WIRING BOARD	EA	1
3	47	PADZZ	5821-168-3624	SM-C-618887	80063	STRIP, GROUNDING	EA	4
3	48	PADZZ	5821-168-3625	SM-C-632174	80063	STRIP, GROUNDING	EA	1
3	49	PADZZ	5935-111-1881	SMA-595807-1	80063	CONNECTOR, ELECTRICAL	EA	5
3	50	PADZZ	5320-680-4039	MS16535-67	96906	RIVET	EA	10
3	51	PADZZ	5310-224-9388	SM-C-596378-20	80063	WASHER, FLAT	EA	20
3	52	PADZZ	5310-181-6034	SM-C-617837-12	80063	WASHER, FLAT	EA	10
3	53	PAFZZ	5821-091-9 163	SMB-618886	80063	COVER AND SHIELD	EA	1
3	54	PAFZZ	5310-933-8120	MS35337-77	96906	WASHER, LOCK	EA	11
						GROUP 02		
						EAR SECTION		
4	1	PAHZZ	5305-054-5636	MS51957-2	96906	SCREW, MACHINE	EA	8
4	2	PAHZZ	5340-182-9709	SM-C-596013-0	80063	SPACER, THREAD	EA	4
4	3	XDHZZ		SMB-597805-3	80063	NUT, PLAIN, HEX	EA	1
4	4	PAHZZ	5310-929-6395	MS35338-136	96906	WASHER, LOCK	EA	2
4	5	PAHZZ	5310-143-5663	SM-C-617837-3	80063	WASHER, FLAT	EA	8
4	6	PAHZZ	5310-933-8120	MS35337-77	96906	WAHER, LOCK	EA	6
4	7	PAHZZ	5305-763-3357	MS51959-6	96906	SCREW, MACHINE	EA	4
						GROUP 0201		
4	8	PAHDL	5821-1.77-2909	SMB-692861	80063	MODULATOR ASSY	EA	1
4	9	PAHZZ	5340-874-2451	SMB-618683-3	80063	CLAMP, LOOP	EA	1
4	10	XAHZZ		SMB-632242	80063	COVER, EXCITER	EA	1



EL 5821-260-24P-TM-3

Figure 3. Front Section Modules and Hardware
2-8

SECTION II

REPAIR PARTS LIST (Continued)

(1) ILLUSTRATION		(2)	(3)	(4)	(5)	(6)	(7)	(8)
(a) FIG NO.	(b) ITEM NO.	SMR CODE	FEDERAL STOCK NUMBER	PART NUMBER	FSCM	DESCRIPTION <i>USABLE ON CODE</i>	U/M	QTY INC IN UNIT
4	11	PAHZZ	5340-793-1671	SMB-618442	80063	BUSHING, GROUND GROUP 0202	EA	1
4	12	PAHHL	5821-724-1706	SMB-632240	80063	EXCITER, POWER AMPLIFIER ASSY	EA	1
4	13	PAHZZ	5950-042-9865	MS75008-28	96906	CHOKE, MOLDED	EA	1
4	14	PAHZZ	5940-615-6073	MS77072-3	96906	TERMINAL, LUG	EA	1
4	15	PAHZZ	5935-762-0414	SMA-595802-4	80063	CONNECTOR, PLUG	EA	1
4	16	PAHZZ	5307-150-4209	SMC-618830-5	80063	SPACER, SLEEVE	EA	4
4	17	PAHZZ		SME-595959-2	80063	WASHER, NONMETALLIC	EA	2
4	18	PAHZZ		SMC-596095-6	80063	SPACER, SLEEVE	EA	2
4	19	PAHZZ	5999-116-2776	SMB-617289	80063	HEAT SINK	EA	2
4	20	PAHZZ	5310-934-9740	MS35649-225	96906	NUT, HEX	EA	4
4	21	PAHZZ	5310-022-1117	MS35333-103	96906	WASHER, LOCK GROUP 0203	EA	4
4	22	PAHZZ	5821-142-5513	SMB-692557	80063	POWER SUPPLY	EA	1
4	23	PAHZZ	5999-061-3276	SMA-617935-2	80063	CONTACT, ELECTRICAL	EA	36
4	24	PAHZZ	5935-134-5297	SMA-617934-1	80063	CONNECTOR, PLUG	EA	1
4	25	PAHZZ	5821-168-3621	SM-C-632342	80063	SUPPORT	EA	1
4	26	PAHZZ	5305-054-5639	MS15795-5	96906	SCREW, MACHINE	EA	4
4	27	PAHZZ	5310-595-6761	MS15795-802	96906	WASHER, FLAT	EA	4
4	28	PAHZZ	5970-935-8169	SMC-596085-6	80063	INSULATOR, BUSHING	EA	4
4	29	PAHZZ	5940-050-2308	MS35431-3	96906	TERMINAL, LUG	EA	2
4	30	PAHZZ	5961-926-0220	2N3792	80131	TRANSISTOR	EA	1
4	31	PAHZZ	5961-127-9362	SMA-618687-1	80063	TRANSISTOR	EA	1
4	32	PAHZZ	5940-023-6246	SMB-595918-2	80063	INSULATOR	EA	1
4	33	PAHZZ	5970-023-6246	SMB-595918-1	80063	INSULATOR	EA	1
4	34	PAHZZ	5305-054-5648	MS51957-14	96906	SCREW, MACHINE	EA	5
4	35	PAHZZ	5310-550-3715	MS35333-70	96906	WASHER, LOCK	EA	1
4	36	PAHZZ	5940-113-9828	MS25036-48	96906	TERMINAL, LUG	EA	3
4	36A	PAFZZ	5305-151-6948	70A3810207-480	00011	SCREW, MACHINE	EA	1
4	36B	PAFZZ	5310-126-0014	SMC-617837-8	80063	WASHER, FLAT	EA	9
4	37	PAHZZ	5821-168-7745	SMB-692772	80063	PLATE, ELECTRICAL	EA	1
4	38	PAHZZ	5821-727-4249	SMC-618423-2	80063	PIN, COVER, RETAINING	EA	2
4	39	PAHZZ	5365-182-4640	SMB-618840	80063	SHIM	EA	4
4	40	PAHZZ	5305-764-2964	MS51959-4	96906	SCREW, MACHINE GROUP 0204	EA	4
4	41	PAHHL	5821-134-6994	SMB-692950	80063	RFCOUPLER AND FILTER ASSY NOTE: REFER TO FIG 5 FOR PARTS BREAKDOWN	EA	1
4	42	PAHZZ	5305-022-6331	SMB-613257	80063	SCREW, SPECIAL	EA	2
4	43	PAHZZ	5310-722-5998	MS15795-805	96906	WASHER, FLAT	EA	2
4	44	PAHZZ	5330-411-2986	SMC-692615	80063	GASKET, CONNECTOR	EA	1
4	45	PAHZZ	5975-177-2133	SMC-632311	80063	ADAPTER, CONNECTOR	EA	1

SECTION II

REPAIR PARTS LIST (Continued)

(1) ILLUSTRATION		(2)	(3)	(4)	(5)	(6)	(7)	(8)
(a) FIG NO.	(b) ITEM NO.	SMR CODE	FEDERAL STOCK NUMBER	PART NUMBER	FSCM	DESCRIPTION <i>USABLE ON CODE</i>	U/M	QTY INC IN UNIT
4	46	PAHZZ	5330-150-9433	SM-C-692614	80063	GASKET, CONNECTOR	EA	1
4	47	PAHZZ	5935-223-2833	SM-C-618678-1	80063	CONNECTOR, RECEPTACLE	EA	1
4	48	PAHZZ	5310-933-8118	MS35338-135	96906	WASHER, LOCK	EA	8
4	49	PAHZZ	5305-054-5647	MS51957-13	96906	SCREW, MACHINE	EA	4
4	50	PAHZZ	5920-902-6827	SMA-595875-1	80063	FUSEHOLDER NOTE: INCLUDES ITEMS 51-52-53	EA	1
4	51	PAHZZ	5310-168-7322	SMB-617939-4	80063	NUT, KNURLED	EA	1
4	52	PAOZZ	5920-903-1008	SM-A-595876-2	80063	FUSE	EA	1
4	53	PAOZZ	5920-110-7 800	SMA-595875-2	80063	CAP	EA	1
4	54	PAHZZ	5310-837-1381	NAS671C8	80205	NUT, PLAIN, HEX	EA	5
4	55	PAHZZ	5935-728-5614	MS27335TB 18-32P	96906	CONNECTOR, RECEPTACLE	EA	1
4	56	PAFZZ	5305-410-6549	SM-C-692567	80063	SCREW, SPECIAL	EA	2
4	57	PAFZZ	5310-929-6395	MS35338-136	96906	WASHER, LOCK	EA	2
4	58	PAFZZ	5310-722-5998	MS15795-805	96906	WASHER, FLAT	EA	2
4	59	PAFZZ	5305-143-1869	SM-C-597739	80063	SCREW, SPECIAL	EA	2
5	1	XADZZ		SMB-618734	80063	RFCOUPLER AND FILTER ASSY, REPAIR PARTS	EA	1
5	2	PADZZ	5305-054-5637	MS51957-3	96906	SCREW, MACHINE	EA	5
5	3	PADZZ	5310-928-2690	MS35338-134	96906	WASHER, LOCK	EA	5
5	4	PADZZ	5310-143-5663	SM-C-617837-3	80063	WASHER, FLAT	EA	5
5	5	PADZZ	5821-724-1713	SMB-618351	80063	CIRCUIT CARD ASSEMBLY, R FCOUPLER	EA	1
5	6	PADZZ	5935-782-6166	SMA-595804-1	80063	CONNECTOR, RECEPTACLE NOTE: INCLUDES NUT/WASHER	EA	1
5	7	PAHZZ	5340-874-2451	SMA-618683-3	80063	CLAMP, LOOP	EA	1
5	8	PADZZ	5821-724-1711	SMB-618293	80063	CIRCUIT CARD ASSEMBLY, LOWPASS FILTER	EA	1
5	9	MDHZZ		SM-C-618213	80063	COVER, ELECTRICAL EQUIPMENT	EA	1
5	10	PADZZ	5305-054-5636	MS51957-2	96906	SCREW, MACHINE	EA	3
5	11	PAHZZ	5935-762-0412	SMA-595802-3	80063	CONNECTOR, PLUG	EA	1
5	12	XAHZZ		SM-C-632302	80063	SUPPORT, CONNECTOR	EA	1
5	13	PAHZZ	5325-174-5317	MS35489-4	96906	GROMMET	EA	1
5	14	PAHZZ	5945-929-9969	SMA-617905	80063	RELAY, COAXIAL	EA	1
5	15	PAHZZ	5305-054-5636	MS51957-2	96906	SCREW, MACHINE	EA	1
5	16	PAHZZ	5310-880-7010	MS21042L02	96906	NUT, SELF LOCKING, HEX	EA	2
5	17	PAHZZ	5915-116-2766	SMA-595904-5	80063	SUPPRESSOR	EA	3
5	18	PAHZZ	5961-924-6981	1N4003	80131	SEMICONDUCTOR DEVICE	EA	1
5	19	PAHZZ	5910-838-9421	CK60AW1O2M	81349	CAPACITOR, FIXED	EA	4
5	20	PAHZZ	5905-681-9969	RC07GF332K	81349	RESISTOR, FIXED	EA	1
5	21	PAHZZ	5935-728-5605	SMA-595805-2	80063	CONNECTOR, RECEPTACLE NOTE: INCLUDES NUT/WASHER	EA	1
5	22	MDHZZ		SMB-692964	80063	SHIM, SPECIAL	EA	1

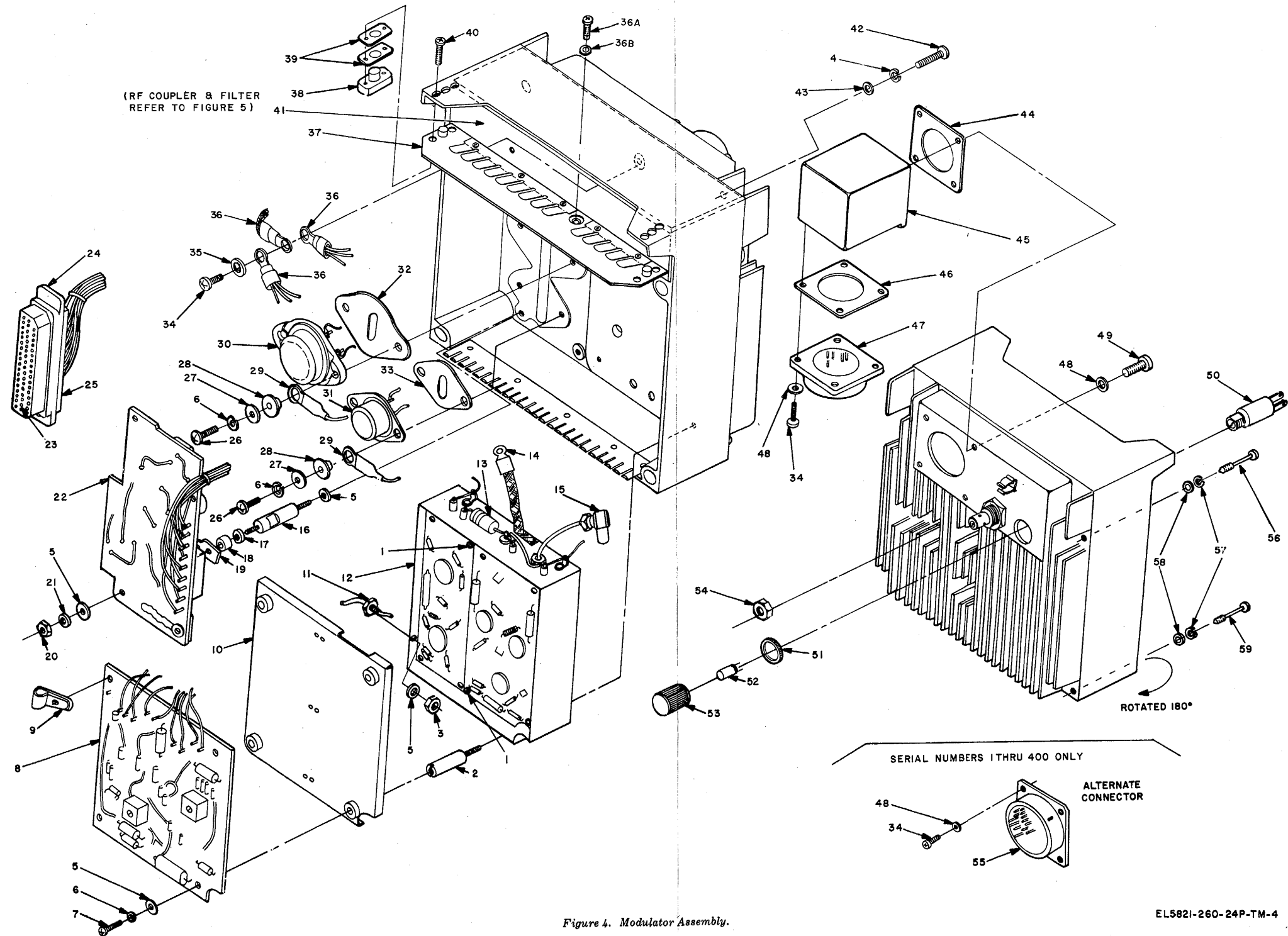
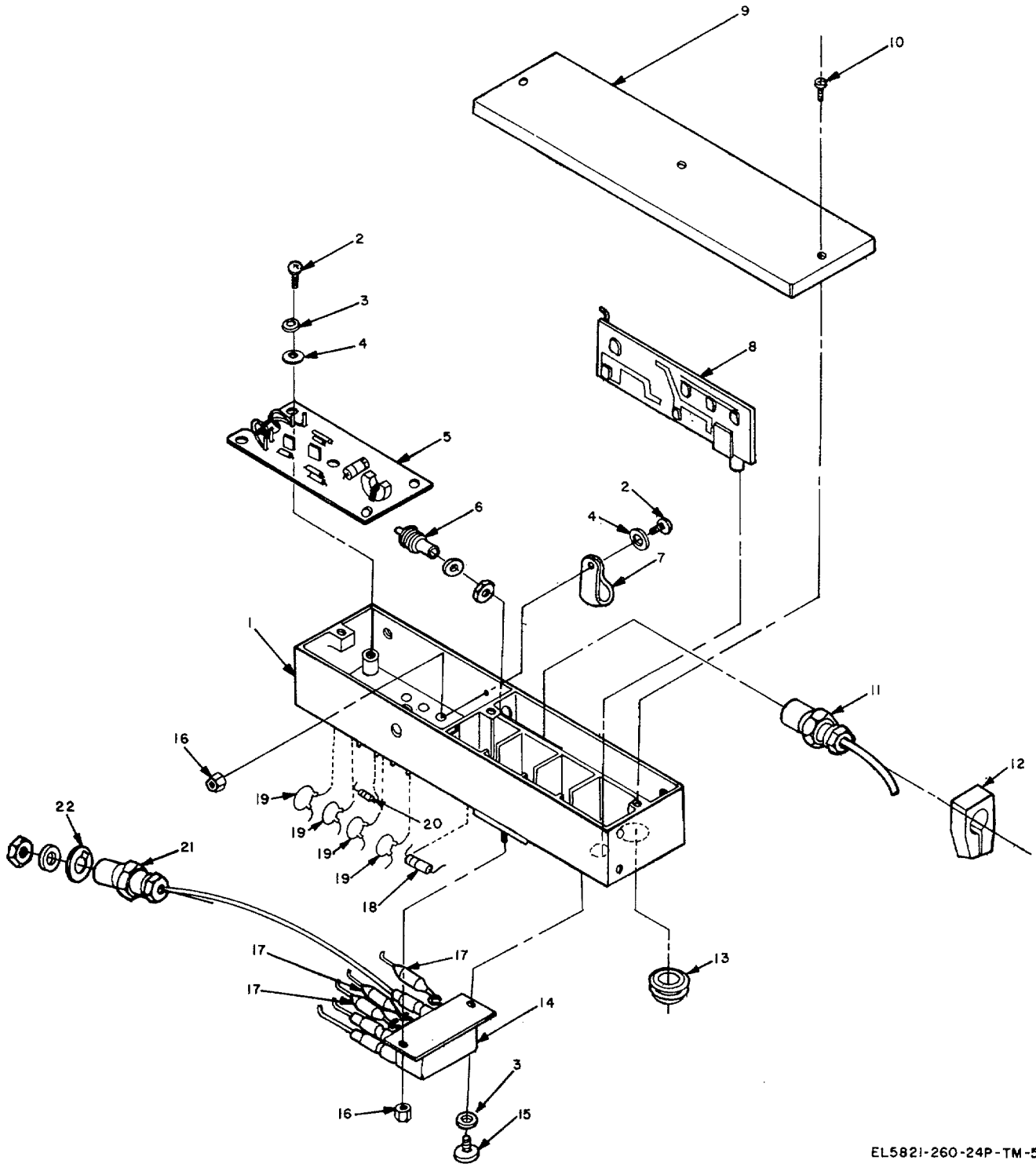

Figure 4. Modulator Assembly.

EL5821-260-24P-TM-4

Figure 4. Modulator Assembly.
(Located in back of manual)



EL5821-260-24P-TM-5

Figure 5. RF Coupler and Filter Assembly
2-12

SECTION II

REPAIR PARTS LIST (Continued)

(1) ILLUSTRATION		(2)	(3)	(4)	(5)	(6)	(7)	(8)
(a) FIG NO.	(b) ITEM NO.	SMR CODE	FEDERAL STOCK NUMBER	PART NUMBER	FSCM	DESCRIPTION <i>USABLE ON CODE</i>	U/M	QTY INC IN UNIT
BULK		PAHZZ	6145-168-3851	19-901910-2099	24868	GROUP 99		
BULK		PAHZZ	6145-168-3852	19-901910-2699	24868	BULK MATERIAL		
BULK		PAHZZ	6145-177-4700	SMA-617943-24	80063	WIRE, ELECTRICAL, WHITE	FT	
BULK		PAHZZ	6145-177-4703	SMA-597811-8	80063	WIRE, ELECTRICAL, WHITE	FT	
BULK		PAHZZ	6145-177-1729	MIL-W-16878/13	81349	WIRE, ELECTRICAL, WHITE, SILVER PLATED	FT	
BULK		PAHZZ	6145-177-4730	TYPE KT, FEP		24 AWG, 19 STRANDS		
BULK		PAHZZ	6145-295-2809	JAC 26 AWG		CABLE,	FT	
BULK		PAHZZ	6145-523-1270	SMA-597811-1	80063	WIRE, ELECTRICAL, WHITE	FT	
BULK		PAHZZ	6145-542-6809	MIL-W-16878/11A	81349	CABLE, RF	FT	
BULK		PAHZZ	6145-577-3420	TYPE E, TFE JAC		WIRE, ELECTRICAL, WHITE		
BULK		PAHZZ	6145-669-6564	26 AWG				
BULK		PAHZZ	6145-812-5034	MIT.11-583	81349	WIRE, ELECTRICAL	FT	
BULK		PAHZZ	6145-838-9444	TYPE T2, 28 AWG				
BULK		PAHZZ		SMA-618662-1	80063	WIRE, BRAID, FLAT	FT	
BULK		PAHZZ		QQ-W-343, TYPE	81349	WIRE, ELECTRICAL, TINNED	FT	
BULK		PAHZZ		S 24 AWG				
BULK		PAHZZ		QQ-W-343, TPYE	81349	WIRE, ELECTRICAL, TINNED	FT	
BULK		PAHZZ		22 AWG				
BULK		PAHZZ		RG1788/U	81349	CABLE, RF	FT	
BULK		PAHZZ		QQ-W-343, TYPE	81349	WIRE, ELECTRICAL, TINNED	FT	
BULK		PAHZZ		S 26 AWG				

SECTION III

SPECIAL TOOLS LIST

(1) ILLUSTRATION		(2)	(3)	(4)	(5)	(6)	(7)	(8)
(a) FIG NO.	(b) ITEM NO.	SMR CODE	FEDERAL STOCK NUMBER	PART NUMBER	FSCM	DESCRIPTION <i>USABLE ON CODE</i>	U/M	QTY INC IN UNIT
6		PEHDL	5821-134-5957	SMB-692766	80063	FILTER - RELAY ASSEMBLY	EA	1
6		PEHDL	5821-168-3614	73-164209-1	14850	VSWR LOAD, 10:1	EA	1
7		PEFFD	5821-456-5996	SMB-692594	80063	RADIO SET, REAR, AN/ARC-115	EA	1
7		PEFFD	5821-456-5997	SMB-692592	80063	RADIO SET, FRONT, AN/ARC-115	EA	1
		PEFFD	6625-179-1699	SMD-664533	80063	MAINTENANCE ACCESSORIES KIT MK-1192/ARM	*	EA
		PEHHD	6625-179-2528	SMB-625821	80063	TEST FACILITIES KIT, MK-1191/AR	*	EA
		PEFFD	6625-802-7191	SMB-625661	80063	TEST FACILITIES KIT, MK-994/AR	*	EA
						* NOTE : FOR AUTHORIZED QUANTITIES, REFER TO TM 11-5821-259-35P, SECTION III, SPECIAL TOOLS LIST, RADIO SET AN/ARC-114.		

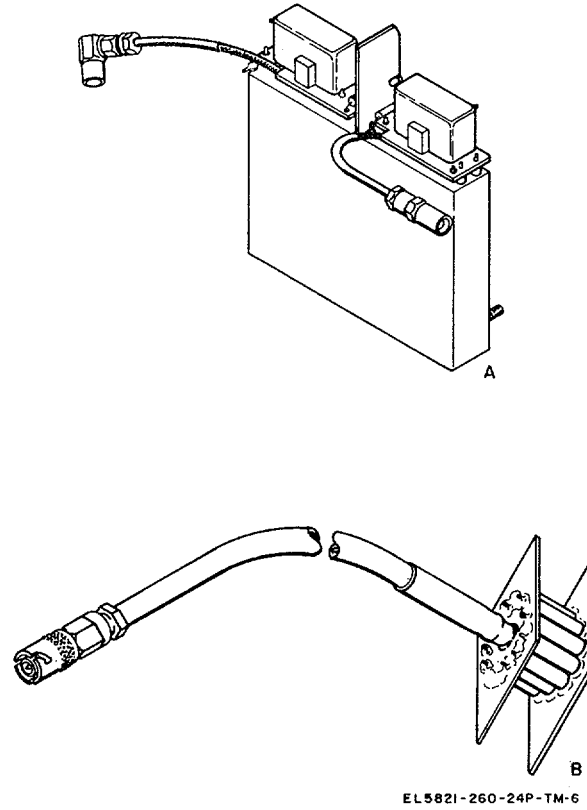
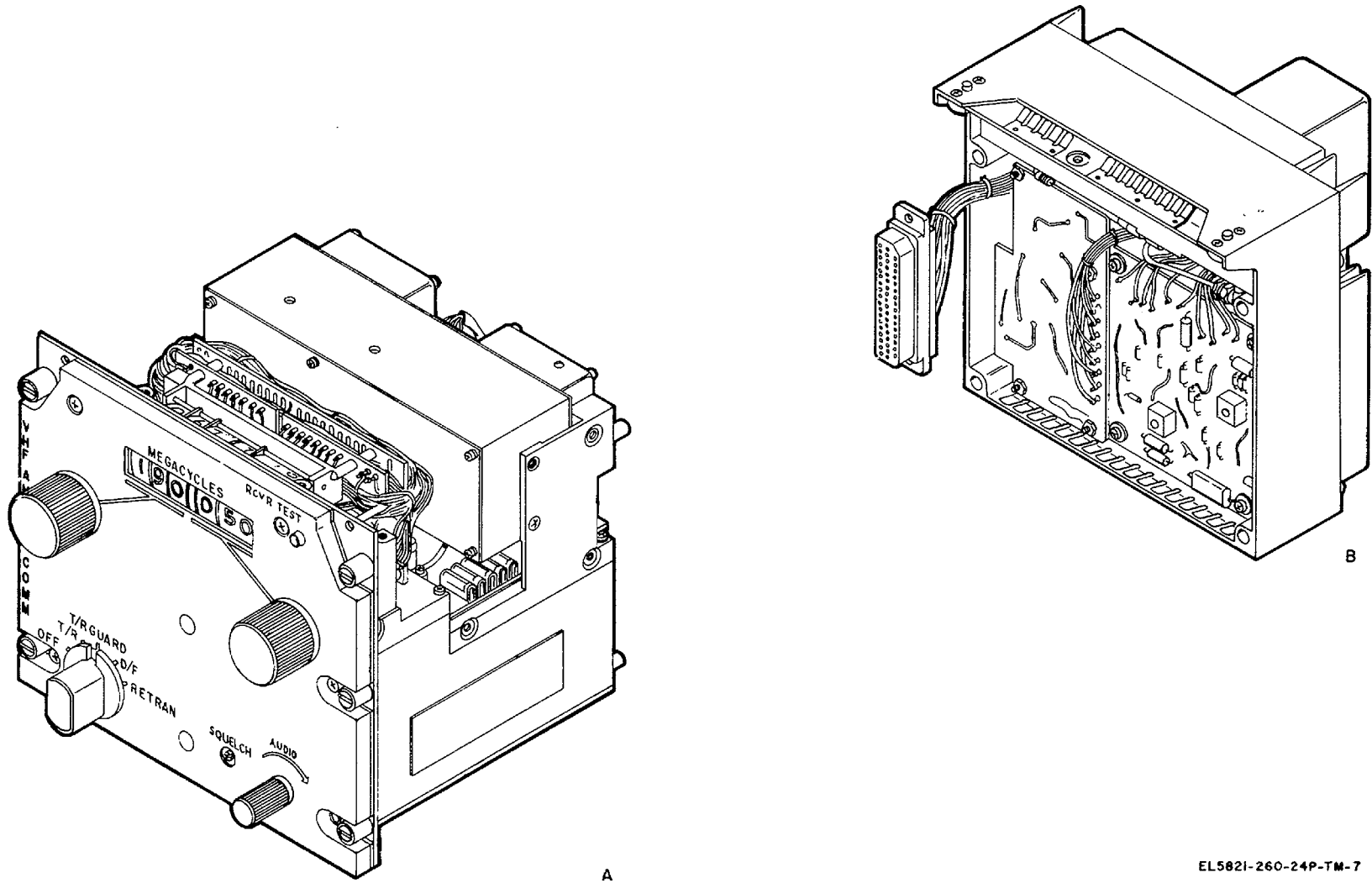

Figure 6. Filter-relay assembly and VSWR load, 10:1.



EL5821-260-24P-TM-7

Figure 7. Radio set, front and rear, AN/ARC-115.

3-3(3-4 blank)

SECTION IV FEDERAL STOCK NUMBER AND PART NUMBER INDEX

STOCK NUMBER	FIG. NO.	ITEM NO.	STOCK NUMBER	FIG. NO.	ITEM NO.
3020-102-3767	1	69	5305-054-5643	2	4
3020-102-3768	1	68	5305-054-5647	4	49
3020-106-9892	1	32	5305-054-5648	4	34
3020-106-9893	1	66	5305-054-5656	1	79
3020-107-3221	1	25	5305-054-9228	1	22A
3040-091-9133	1	38	5305-068-5414	1	65
3040-091-9134	1	60	5305-143-1869	4	59
3040-181-3214	1	26	5305-151- 6948	4	36A
3120-116-1474	1	22	5305-410-6549	4	56
3120-809-6560	1	70	5305-411-0681	1	53
3120-809-6561	1	28	5305-717-6950	1	2
5305-012-0719	1	47	5305-717-6955	1	23
5305-022-6331	4	42	5305-719-5342	1	6
5305-054-5636	1	83	5305-719-5346	1	4
5305-054-5636	2	7	5305-719-5349	1	7
5305-054-5636	4	1	5305-727-8833	3	9
5305-054-5636	5	10	5305-763-3357	4	7
5305-054-5636	5	15	5305-763-7822	1	15
5305-054-5637	1	51	5305-764-2964	4	40
5305-054-5637	2	2	5305-812-6079	1	42
5305-054-5637	3	24	5307-150-4209	4	16
5305-054-5637	5	2	5310-011-6123	2	13
5305-054-5638	2	10	5310-022-1117	4	21
5305-054-5638	3	21	5310-022-6331	1	9
5305-054-5639	3	12	5310-113-8412	1	85
5305-054-5639	4	26	5310-113-8415	1	18
5305-054-5640	3	36	5310-113-8434	1	22B
5305-054-5641	3	35	5310-115-6273	1	14A

SECTION IV FEDERAL STOCK NUMBER AND PART NUMBER INDEX (Continued)

STOCK NUMBER	FIG. NO.	ITEM NO.	STOCK NUMBER	FIG. NO.	ITEM NO.
5310-126-0014	4	36B	5310-929-6395	1	10
5310-143-1713	5	5	5310-929-6395	1	14B
5310-143-5649	1	21	5310-929-6395	2	18
5310-143-5661	1	12	5310-929-6395	4	4
5310-143-5663	1	40	5310-929-6395	4	57
5310-143-5663	2	3	5310-933-8118	1	78
5310-143-5663	3	20	5310-933-8118	4	48
5310-143-5663	4	5	5310-933-8120	3	54
5310-143-5663	5	4	5310-933-8120	4	6
5310-143-5680	1	34	5310-934-9740	4	20
5310-168-7322	4	51	5310-938-2013	2	25
5310-181-6034	3	52	5315-797-5206	1	31
5310-224-9388	3	51	5315-797-5206	1	67
5310-550-3715	4	35	5320-168-7323	3	13
5310-595-6211	1	76	5320-680-4039	3	50
5310-595-6761	3	23	5325-174-5317	5	13
5310-595-6761	4	27	5330-150-9433	4	46
5310-722-5998	4	43	5330-411-2986	4	44
5310-722-5998	4	58	5340-113-3848	1	17
5310-792-3548	1	84	5340-151-7036	1	20
5310-792-3555	1	19	5340-182-9709	4	2
5310-807-1471	1	75	5340-598-1493	1	11
5310-837-1381	4	54	5340-721-8187	1	16
5310-880-7010	2	12	5340-793-1256	1	27
5310-880-7010	3	15	5340-793-1256	1	71
5310-880-7010	5	16	5340-793-1273	1	50
5310-928-2690	1	41	5340-793-1664	1	30
5310-928-2690	2	1A	5340-793-1671	2	19
5310-928-2690	3	11			
5310-928-2690	5	3			

SECTION IV FEDERAL STOCK NUMBER AND PART NUMBER INDEX (Continued)

STOCK NUMBER	FIG. NO.	ITEM NO.	STOCK NUMBER	FIG. NO.	ITEM NO.
5340-793-1671	4	11	5821-168-3626	1	58
5340-793-1703	1	61	5821-168-7745	4	37
5340-793-1712	1	37	5821-177-1584	2	5
5340-866-1471	1	73	5821-177-2907	3	6
5340-874-2451	3	28	5821-177-2908	3	7
5340-874-2451	4	9	5821-177-2908	3	8
5340-874-2451	5	7	5821-177-2909	4	8
5355-181-1126	1	72	5821-17 7-3504	3	46
5355-880-5546	1	8	5821-177-3510	2	27
5355-880-5548	1	5	5821-177-3511	3	37
5355-880-5549	1	3			
5365-182-4640	4	39			
5821-091-9160	1	13	5821-456-6002	3	1
5821-091-9163	3	53	5821-724-1685	1	1
5821-091-9164	2	23	5821-724-1686	2	1
5821-091-9165	1	48	5821-724-1690	3	42
5821-091-9166	1	52	5821-724-1706	4	12
5821-091-9167	1	49	5821-724-1707	3	5
			5821-724-1711	5	8
5821-134-6994	4	41	5821-724-1713	5	5
5821-142-5437	1	86	5821-727-4249	2	26
5821-142-5513	4	22	5821-727-4249	4	38
5821-142-5546	3	3	5821-727-4253	2	24
5821-142-5549	3	2	5821-727-4264	3	4
			5821-728-8084	2	6
5821-168-3621	4	25	5821-789-3815	1	1A
5821-168-3624	3	47	5821-815-9879	3	22
5821-168-3625	3	48	5821-926-3303	2	16

SECTION IV FEDERAL STOCK NUMBER AND PART NUMBER INDEX (Continued)

STOCK NUMBER	FIG. NO.	ITEM NO.	STOCK NUMBER	FIG. NO.	ITEM NO.
5895-704-9698	1	36	5935-134-5356	1	57
5905-057-8733	1	81	5935-168-4125	3	45
5905-057-8737	1	80	5935-168-4418	1	55
5905-681-9969	5	20	5935-168-7997	3	31
5905-763-4738	3	34	5935-223-2833	4	47
5910-168-3466	3	44	5935-419-5417	3	27
5910-733-6687	3	43	5935-728-5605	5	21
5910-782-4962	3	40	5935-728-5614	4	55
5910-782-5000	2	22	5935-762-0412	5	11
5910-838-9421	5	19	5935-762-0414	4	15
5915-116-2766	5	17	5935-763-0858	3	29
5920-110-7800	4	53	5935-782-6166	5	6
5920-902-6827	4	50	5940-023-6246	4	32
5920-903-1008	4	52	5940-050-2308	4	29
5930-059-2856	1	74	5940-113-9828	4	36
5930-115-8522	1	33	5940-259-9057	2	14
5930-115-8523	1	63	5940-615 -6073	4	14
5930-116-2767	1	59	5945-929-9969	5	14
5930-116-2768	1	44	5950-042-9865	4	13
5930-116-2769	1	43	5961-127-9362	4	31
5930-520-5179	1	35	5961-924-6981	5	18
5930-520-5179	1	62	5961-926-0220	4	30
5935-111-1881	3	49	5970-023-6246	4	33
5935-114-8767	2	9	5970-134-0907	1	45
5935-115-8514	1	56	5970-168-4271	3	39
5935-134-5297	4	24	5970-935-8169	4	28
5935-134-5337	3	19	5975-177-2133	4	45
5935-134-5355	3	14	5985-110-9288	1	14

SECTION IV FEDERAL STOCK NUMBER AND PART NUMBER INDEX (Continued)

STOCK NUMBER	FIG. NO.	ITEM NO.	STOCK NUMBER	FIG. NO.	ITEM NO.
5995-056-8848	2	21			
5995-056-8848	3	38	6680-150-6914	1	29
5995-056-8850	2	20			
5995-056-8850	3	41			
5995-168-3805	3	33			
5995-168-3806	3	32			
5999-061-3276	1	54			
5999-061-3276	3	30			
5999-061-3276	4	23			
5999-062-1608	2	11			
5999-062-1608	3	25			
5999-116-2776	4	19			
5999-168-4021	3	18			
5999-168-4022	3	26			
6145-168-3851	BULK				
6145-168-3852	BULK				
6145-177-4700	BULK				
6145-177-4703	BULK				
6145-177-4729	BULK				
6145-177-4730	BULK				
6145-295-2809	BULK				
6145-523-1270	BULK				
6145-542-6809	BULK				
6145-577-3420	BULK				
6145-669-6564	BULK				
6145-812-5034	BULK				
6145-838-9444	BULK				

SECTION IV FEDERAL STOCK NUMBER AND PART NUMBER INDEX (CONTINUED)

PART NUMBER	FSCM	FIG. NO.	ITEM NO.	PART NUMBER	FSCM	FIG. NO.	ITEM NO.
CK60AW102M	81349	5	19	MS35337-79	96906	2	18
MIL-W-16878/13 TYPE KT, FEP JAC 26 AWG	81349	BULK		MS35338-134	96906	1	41
MIL-W-16878/4A TYPE E, TFE JAC 26 AWG	81349	BULK		MS35338-134	96906	2	1A
				MS35338-134	96906	3	11
				MS35338-134	96906	5	3
MIL-W-583 TYPE T2 28 AWG	81349	BULK		MS35338-135	96906	1	78
ML105C10103M	96905	3	44	MS35338-135	96906	4	48
MS15795-5	96906	4	26	MS35338-136	96906	1	10
MS15795-802	96906	3	23	MS35338-136	96906	1	14B
MS15795-802	96906	4	27	MS35338-136	96906	4	4
MS15795-803	96906	1	76	MS35338-136	96906	4	57
MS15795-805	96906	4	43	MS35338-69	96906	2	13
MS15795-805	96906	4	58	MS35431-3	96906	4	29
MS16535-67	96906	3	50	MS35489-4	96906	5	13'
MS16624-1018	96906	1	16	MS35649-224	96906	2	25
MS16632-4012	96906	1	73	MS35649-225	96906	4	20
MS16632-4018	96906	1	11	MS51957-13	96906	4	49
MS16995-11	96906	1	65	MS51957-14	96906	4	34
MS21042L02	96906	2	12	MS51957-2	96906	1	83
MS21042L02	96906	3	15	MS51957-2	96906	2	7
MS21042L02	96906	5	16	MS51957-2	96906	4	1
MS21042L04	96906	1	75	MS51957-2	96906	5	10
MS25036-48	96906	4	36	MS51957-2	96906	5	15
MS27335TB 18-32P	96906	4	55	MS51957-22	96906	1	79
MS35333-103	96906	4	21	MS51957-3	96906	1	51
MS35333-70	96906	4	35	MS51957-3	96906	2	2
MS35337-77	96906	3	54	MS51957-3	96906	3	24
MS35337-77	96906	4	6	MS51957-3	96906	5	2
				MS51957-4	96906	2	10

SECTION IV FEDERAL STOCK NUMBER AND PART NUMBER INDEX (CONTINUED)

PART NUMBER	FSCM	FIG. NO.	ITEM NO.	PART NUMBER	FSCM	FIG. NO.	ITEM NO.
MS51957-4	96906	3	21	SMA-595805-2	80063	5	21
MS51957-5	96906	3	12	SMA-595807-1	80063	3	49
MS51957-6	96906	3	36	SMA-595807-2	80063	3	45
MS51957-7	96906	3	35	SMA-595811-4	80063	1	74
MS51957-9	96906	2	4	SMA-595837-1	80063	3	41
MS51959-14	96906	1	15	SMA-595862-202	80063	3	34
MS51959-3	96906	3	9	SMA-595875-1	80063	4	50
S51959-4	96906	4	40	SMA-595875-2	80063	4	53
MS51959-6	96906	4	7	SMA-595876-2	80063	4	52
MS51963-1	96906	1	23	SMA-595898-1	80063	2	22
MS51963-34	96906	1	6	SMA-595904-5	80063	5	17
MS51963-35	96906	1	4	SMA-597811-4	80063	BULK	
MS51963-37	96906	1	7	SMA-597811-8	80063	BULK	
MS51963-9	96906	1	2	SMA-597813-3	80063	1	81
MS75008-28	96906	4	13	SMA-597813-5	80063	1	80
MS77072-3	96906	4	14	SMA-597837-1	80063	2	20
NAS1635-00-8	80205	1	47	SMA-597837-2	80063	2	21
NAS1635-02-20	80205	1	42	SMA-597837-2	80063	3	38
NAS671C8	80205	4	54	SMA-617902-3	80063	3	14
QQ-W-343, TYPE S 22 AWG	81349	BULK		SMA-617902-4	80063	1	57
				SMA-617905	80063	5	14
QQ-W-343, TYPE S 24 AWG	81349	BULK		SMA-617920-10	80063	3	19
QQ-W-343, TYPE S 26 AWG	81349	BULK		SMA-617920-3	80063	3	29
RC07GF332K	81349	5	20	SMA-617920-4	80063	2	9
RG1788/U	81349	BULK		SMA-617920-9	80063	1	56
SMA-595791-3	80063	3	43	SMA-617934-1	80063	4	24
SMA-595802-3	80063	5	11	SMA-617934-2	80063	3	27
SMA-595802-4	80063	4	15	SMA-617935-1	80063	2	11
SMA-595804-1	80063	5	6	SMA-617935-1	80063	3	25
				SMA-617935-2	80063	1	54

SECTION IV FEDERAL STOCK NUMBER AND PART NUMBER INDEX (CONTINUED)

PART NUMBER	FSCM	FIG. NO.	ITEM NO.	PART NUMBER	FSCM	FIG. NO.	ITEM NO.
SMA-617935-2	80063	3	30	SMB-618033	80063	2	14
SMA-617935-2	80063	4	23	SMB-618080	80063	1	64
SMA-617935-3	80063	3	26	SMB-618083	80063	1	77
SMA-617935-5	80063	3	18	SMB-618116	80063	1	49
				SMB-618119	80063	1	52
				SMB-618122	80063	1	48
SMA-618683-3	80063	5	7	SMB-618141	80063	3	40
SMA-618687-1	80063	4	31	SMB-618180	80063	3	8
SMB-595918-1	80063	4	33	SMB-618201	80063	3	10
SMB-595918-2	80063	4	32	SMB-618203	80063	3	37
SMB-595940-1	80063	1	31	SMB-618206	80063	3	22
SMB-595940-2	80063	1	67	SMB-618257	80063	1	9
SMB-595946-10	80063	3	13	SMB-618257	80063	4	42
SMB-595947	80063	1	36	SMB-618257-2	80063	1	14A
SMB-595971-1	80063	1	85	SMB-618293	80063	5	8
SMB-596140	80063	2	6	SMB-618297	80063	2	16
SMB-596143	80063	2	26	SMB-618351	80063	5	5
SMB-596347	80063	3	5	SMB-618392	80063	1	39
SMB-597805-3	80063	4	3	SMB-618398	80063	1	13
SMB-597932-4	80063	1	34	SMB-618400	80063	2	1
SMB-617289	80063	4	19	SMB-618404	80063	1	34
SMB-617809-1	80063	1	59	SMB-618442	80063	2	8
SMB-617809-2	80063	1	44	SMB-618442	80063	2	19
SMB-617829-5	80063	1	68	SMB-6184 42	80063	4	11
SMB-617839	80063	1	46	SMB-618546	80063	1	64
SMB-617939-3	80063	1	84	SMB-618683-3	80063	3	28
SMB-617939-4	80063	4	51	SMB-618683-3	80063	4	9
SMB-618008	80063	1	14	SMB-618734	80063	5	1
SMB-618025	80063	1	1	SMB-618840	80063	4	39

SECTION IV FEDERAL STOCK NUMBER AND PART NUMBER INDEX (CONTINUED)

PART NUMBER	FSCM	FIG. NO.	ITEM NO.	PART NUMBER	FSCM	FIG. NO.	ITEM NO.
SMB-618880	80063	3	42	SMC-597739	80063	4	59
SMB-618886	80063	3	53	SMC-617814	80063	1	5
				SMC-617832-2	80063	1	30
				SMC-617837-1	80063	1	12
SMB-632012	80063	2	24	SMC-617837-12	80063	3	52
SMB-632225	80063	3	4	SMC-617837-3	80063	1	40
SMB-632240	80063	4	12	SMC-617837-3	80063	2	3
SMB-632242	80063	4	10	SMC-617837-3	80063	3	20
SMB-692557	80063	4	22	SMC-617837-3	80063	4	5
SMB-692592	80063	7		SMC-617837-3	80063	5	4
SMB-692594	80063	7		SMC-617837-5	80063	1	22B
SMB-692656	80063	3	1	SMC-617837-8	80063	4	36B
SMB-692735	80063	3	7	SMC-617856	80063	1	33
SMB-692766	80063	6		SMC-617857	80063	1	63
SMB-692772	80063	4	37	SMC-617878-2	80063	1	61
SMB-692861	80063	4	8	SMC-617878-3	80063	1	37
SMB-692882	80063	3	6	SMC-618048-1	80063	1	19
SMB-692950	80063	4	41	SMC-618048-2	80063	1	18
SMB-692955	80063	1	24	SMC-618053-1	80063	1	17
SMB-692964	80063	5	22	SMC-618063	80063	1	66
SMB-693079	80063	3	2	SMC-618064	80063	1	22
SMB-693081	80063	3	3	SMC-618066-2	80063	1	28
SMC-596013-10	80063	4	2	SMC-618066-3	80063	1	70
SMC-596085-6	80063	4	28	SMC-618089	80063	1	20
SMC-596095-12	80063	1	50	SMC-618094	80063	3	16
SMC-596095-6	80063	4	18	SMC-618213	80063	5	9
SMC-596378-1	80063	1	21	SMC-618218	80063	1	43
SMC-596378-20	80063	3	51	SMC-618407	80063	1	3
SMC-597677	80063	1	45	SMC-618423-2	80063	4	38

SECTION IV FEDERAL STOCK NUMBER AND PART NUMBER INDEX (CONTINUED)

PART NUMBER	FSCM	FIG. NO.	ITEM NO.	PART NUMBER	FSCM	FIG. NO.	ITEM NO.
SMC-618436	80063	2	23	SMD-617888-2	96906	1	25
SMC-618439	80063	2	17	SMD-618082	80063	1	32
SMC-618500	80063	1	27	SMD-618087	80063	1	35
SMC-618548	80063	1	26	SMD-618087	80063	1	
SMC-618549	80063	1	72	SMD-618266	80063	3	17
SMC-618550	80063	1	71	SMD-618638	80063	3	32
SMC-618678	80063	4	47	SMD-618639	80063	3	33
SMC-618826	80063	2	5	SMD-632010	80063	3	46
SMC-618827	80063	2	27	SMD-664533	80063		
SMC-618830-5	80063	4	16	SME-595959-2	80063	4	17
SMC-618887	80063	3	47	SME-618092-1	80063	1	1A
SMC-618889-1	80063	1	82	SME-618092-2	80063	1	86
SMC-632174	80063	3	48	SME-618403	80063	2	15
SMC-632302	80063	5	12	1N4003	80131	5	18
SMC-632311	80063	4	45				
SMC-632342	80063	4	25				
SMC-632343	80063	1	35	2N3792	80131	4	30
SMC-632344	80063	1	58	70A3210218-480	00011	1	53
SMC-632345	80063	3	31	70A3810207-480	00011	4	36A
SMC-692567	80063	4	56	70A3810406-480	00011	1	22A
SMC-692614	80063	4	46	73-164209-1	14850	6	
SMC-692615	80063	4	44				
SMC-692753	80063	3	39				
SMD-595976-2	80063	1	29				
SMD-595979-3	80063	1	8				
SMD-617842-1	80063	1	60				
SMD-617842-2	80063	1	38				
SMD-617888-1	80063	1	69				

By Order of the Secretary of the Army:

CREIGHTON W. ABRAMS
General, United States Army
Chief of Staff

Official:

VERNE L. BOWERS
Major General, United States Army
The Adjutant General

DISTRIBUTION:

To be distributed in accordance with DA Form 1236, (qty rqr block no. 130) Organizational maintenance requirements for AN/ARC-115.

☆ U. S. GOVERNMENT PRINTING OFFICE : 1992 O - 311-831 (43967)

RECOMMENDED CHANGES TO EQUIPMENT TECHNICAL PUBLICATIONS



*THEN...JOT DOWN THE
DOPE ABOUT IT ON THIS FORM.
CAREFULLY TEAR IT OUT, FOLD IT
AND DROP IT IN THE MAIL.*

SOMETHING WRONG WITH PUBLICATION

FROM: (PRINT YOUR UNIT'S COMPLETE ADDRESS)

DATE SENT

PUBLICATION NUMBER

PUBLICATION DATE

PUBLICATION TITLE

BE EXACT PIN-POINT WHERE IT IS

PAGE NO.	PARA- GRAPH	FIGURE NO.	TABLE NO.

IN THIS SPACE, TELL WHAT IS WRONG
AND WHAT SHOULD BE DONE ABOUT IT.

PRINTED NAME, GRADE OR TITLE AND TELEPHONE NUMBER

SIGN HERE

PIN: 022995-000